

CSA Approved
cUL Listed for Wet Locations

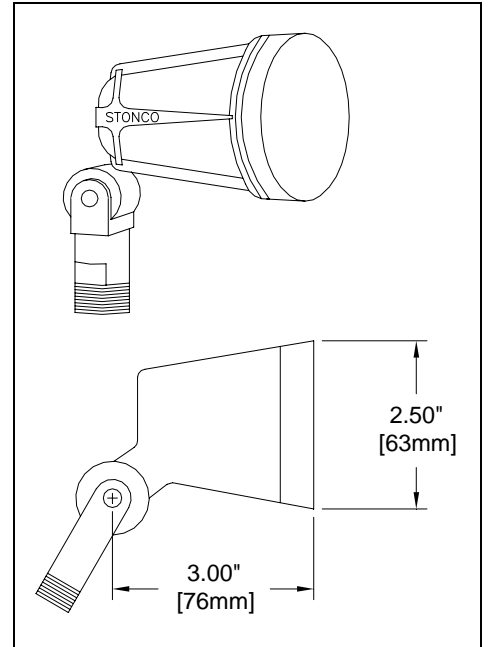

SPECIFICATIONS:

- Lampholder constructed of weatherproof, corrosion-proof die-cast zinc. Equipped with a locked-in three part aluminum/silicone rubber/fiberglass "Cushion Seal" lamp gasket.
- Arm is constructed of die-cast aluminum with threaded male end for 1/2" NPT; fully adjustable with degree marked aiming quadrant, serrated gripping teeth and heavy locknut.



ORDERING GUIDE:

Catalogue Number	Wattage	Finish	Lamp
3100	75-150W	Zinc	Par 38
3100B	75-150W	Black	Par 38

PROJECT: _____

TYPE: _____ CATALOGUE NUMBER: _____